

Specifications/Dimensions

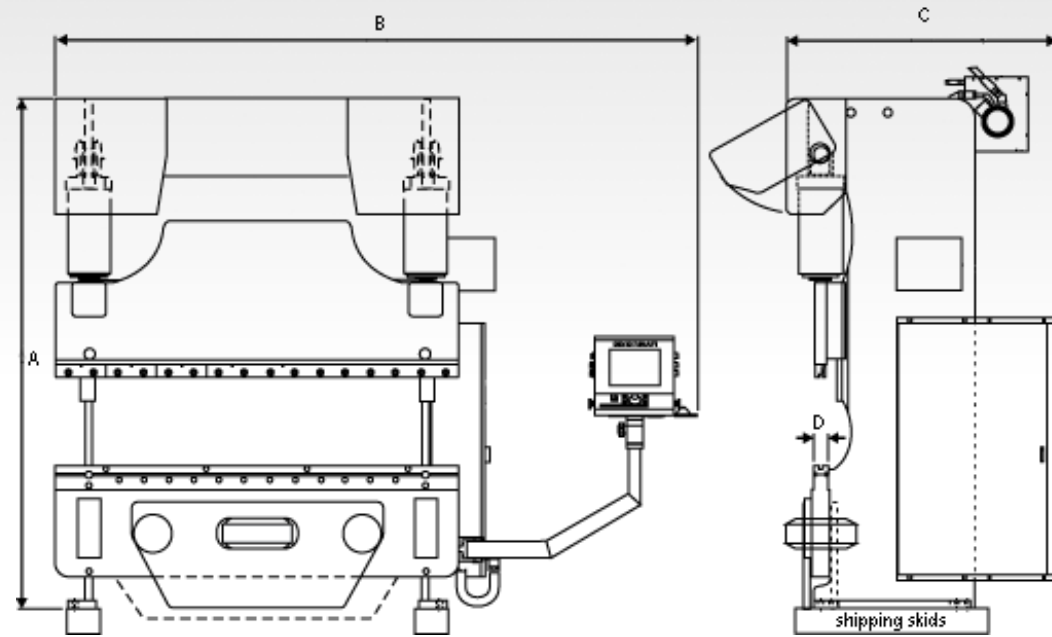

Model	Distance between housings -in.	Closed Height -in.	Stroke Length -in.	Open Height -in.	Approach Speed -ipm.	Forming Speed -ipm.	Return Speed -ipm.	Motor -HP	Height -in. (A)	Width -in. (B)	Depth -in. (C)	Bed Top Width -in. (D)	Domestic Shipping Weight -lbs
90MX6	78.5	7	8	15	700	1 TO 75	1 TO 565	20	109.5	150	65	3.5	14,300
90MX8	102.5	7	8	15	700	1 TO 75	1 TO 565	20	109.5	174	65	3.5	16,800
90MX12	126.5	7	8	15	700	1 TO 75	1 TO 565	20	109.5	198	65	3.5	19,300
135MX6	78.25	7	8	15	700	1 TO 55	1 TO 540	25	110.1	150	65	3.5	15,800
135MX8	102.3	7	8	15	700	1 TO 55	1 TO 540	25	110.1	174	65	3.5	18,000
135MX10	126.3	7	8	15	700	1 TO 55	1 TO 540	25	110.1	198	65	4.5	20,800
135MX12	150.3	7	8	15	700	1 TO 55	1 TO 540	25	110.1	222	65	4.5	24,800
175MX6	78.75	7	10	17	600	1 TO 45	1 TO 485	25	123.5	150	67	4.5	19,500
175MX8	102.8	7	10	17	600	1 TO 45	1 TO 485	25	123.5	174	67	4.5	22,000
175MX10	126.8	7	10	17	600	1 TO 45	1 TO 485	25	123.5	198	67	4.5	25,500
175MX12	150.8	7	10	17	60	1 TO 45	1 TO 485	25	123.5	222	67	4.5	30,000
230MX6	78.5	7	10	17	600	1 TO 35	1 TO 430	25	126.3	150	67	5.5	23,500
230MX8	102.5	7	10	17	600	1 TO 35	1 TO 430	25	126.3	174	67	5.5	26,300
230MX10	126.5	7	10	17	600	1 TO 35	1 TO 430	25	126.3	198	67	5.5	30,200
230MX12	150.5	7	10	17	600	1 TO 35	1 TO 430	25	126.3	222	67	5.5	34,500
350MX8	102	7	10	18	500	1 TO 30	1 TO 330	25	133.6	174	81	5.5	35,300
350MX10	126	7	10	18	500	1 TO 30	1 TO 330	25	133.6	198	81	5.5	39,600
350MX12	150	7	10	18	500	1 TO 30	1 TO 330	25	133.6	222	81	5.5	45,000

* Requires slot in floor

CINCINNATI® follows the policy of continuous advancement in product development. For this reason, specifications and dimensions are for reference only and can change without notice. Foundation plans are furnished with each new machine installation.

CINCINNATI®
CINCINNATI INCORPORATED

www.e-ci.com

Box 11111, Cincinnati, OH 45211
Phone: (513) 367-7100
Fax: (513) 367-7552
E-mail: info@e-ci.com

CINCINNATI®

MAXFORM



MAXFORM

The **CINCINNATI** MAXFORM includes the following key features:

- ✓ Ultra-fast speeds
- ✓ ±.0002" (3-sigma) ram repeatability
- ✓ PC operator control with visual work instructions
- ✓ Graphical tool library with pre-loaded tool files
- ✓ Touchscreen interface
- ✓ Hardened bolt-on ram nose
- ✓ Standard 5-Axis or optional 6-Axis LT backgag
- ✓ Dynamic thickness compensation
- ✓ Bend simulation module software (control and offline)
- ✓ Five-year machine warranty



Offline programming



Model 90MX8
Some optional items shown

www.e-ci.com

Features / Options

Standard Features

- ✓ Industrial computer based HMI control with Windows®
- ✓ 15" color LCD display with touchscreen interface
- ✓ Keyboard and pointing device
- ✓ Hard drive
- ✓ Ethernet and USB convenience outlets
- ✓ Forming modes: angle, tonnage, position, absolute position, angle/DTC
- ✓ Adaptive mode (standard with AUTO CROWN®)
- ✓ English / Spanish display
- ✓ Operator controls: one foot switch, one palm button station
- ✓ Programmable ram tilt
- ✓ Inch / metric display
- ✓ Graphical tool library with pre-loaded tool files
- ✓ Bend simulation module (control and offline)
- ✓ Batch program operation
- ✓ Backup and restore wizard
- ✓ Dual English and metric rule on ram
- ✓ Automatic level control with dual .00002" resolution encoders
- ✓ Tonnage control with dual strain gages
- ✓ Full length dovetail slot in front and back of bed
- ✓ Bed machined for angle brackets
- ✓ Microcrowned bed
- ✓ Quick clamp ram nose, bolt-on, hardened, die clamp bolts on 6" centers
- ✓ One set of die aligners
- ✓ Clevis mounted hydraulic cylinders with hardened piston rods
- ✓ Hydraulic oil and filters
- ✓ Management display information: counters, cycle time
- ✓ Maintenance messages, machine diagnostics, oil level / temperature sensing
- ✓ Web enabled machine monitoring
- ✓ E-mail notification of machine faults
- ✓ Electrical: 460/3/60
- ✓ Operator training at Cincinnati Incorporated
- ✓ 5-Axis backgag (max 12' range between housings)
- ✓ Paint – tech beige (with black covers and accents)
- ✓ Five year parts warranty, one year labor, control and CNC gages

Options

- ✓ Increased stroke, closed height, throat
- ✓ Bed and ram extensions
- ✓ Power clamp upper, lower
- ✓ Programmable AUTO CROWN®, CNC crownable filler blocks
- ✓ Filler blocks
- ✓ Voltage: 208/3/60, 230/3/60, 575/3/60
- ✓ Additional operator controls
- ✓ Programmable palm button / foot switch
- ✓ Presence sensing interface and device
- ✓ Area work light
- ✓ Pedestal mounted control
- ✓ Programmable outputs
- ✓ Robot interface
- ✓ Work supports - standard or fast setup
- ✓ 6-Axis LT backgag
- ✓ CNC plate gage
- ✓ CNC front gage
- ✓ Air-cooled heat exchanger
- ✓ Heater unit for hydraulic tank
- ✓ Paint color
- ✓ Tandem configuration
- ✓ CSA Z142-02 compliance

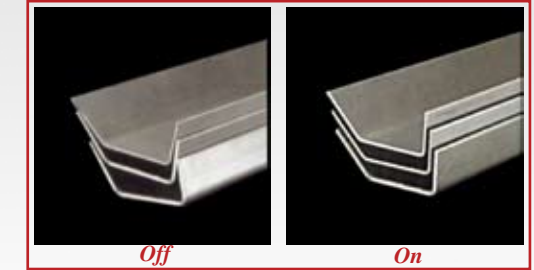

Dynamic Thickness Compensation and optional Adaptive Mode



Optional increased closed height / increased stroke



Optional Fast Setup Work Supports



Optional CNC Crownable Filler Block

www.e-ci.com

High Standards

Machine Design

- ✓ Heavy-duty steel frame with interlocked construction eliminates load-bearing welds
- ✓ Linear steel ram guides and self lubricating slide liners
- ✓ Clevis mounted cylinders and hardened piston rods
- ✓ Large capacity hydraulic tank
- ✓ Manifold block hydraulics for simple maintenance
- ✓ Reduced noise, high-speed hydraulic system



90MX8 with Optional Presence Sensing Device

Safety Features

- ✓ Guarded foot switch
- ✓ Dual palm button operator station with E-stop and ram direction lights
- ✓ Hand/Foot sequence
- ✓ Tool overload protection
- ✓ ON/Off operator key switch
- ✓ Tonnage and speed limited setup mode
- ✓ ANSI B11.3-2002 compliance
- ✓ Optional presence sensing device interface or factory installed presence sensing devices
- ✓ Redundant hydraulic circuitry

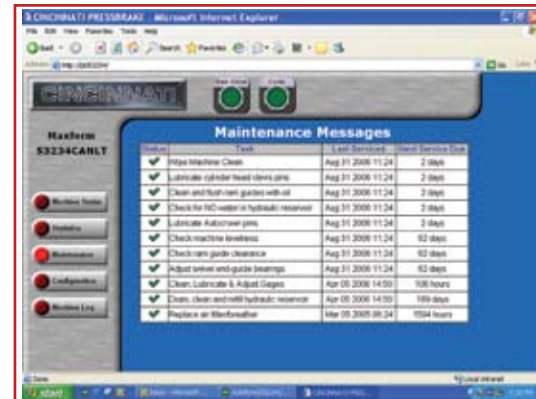

Web-based Remote Machine Monitoring



Customer Information Center

Support

- ✓ Field-based factory service representatives
- ✓ Technical service telephone support
- ✓ Part inventory located in Harrison, OH
- ✓ Web-based remote machine monitoring
- ✓ Operator and maintenance training programs available at Cincinnati Incorporated or at your facility
- ✓ Visit our Web site www.e-ci.com for all the latest GINGINNATI information, software demonstrations or try the online tonnage calculator. GINGINNATI users are invited to register on the Customer Information Center to track parts orders, download software updates and manuals.

Fast, Repeatable Setups

Visual Work Instructions

The graphical control provides visual work instructions. Easy to understand instructions shorten the learning curve and reduce operator errors.



PC Operator Control

The GINGINNATI operator interface was developed to provide fast, repeatable setups. Windows® based software and a touch-screen LCD display eliminate two-thirds of the programming steps compared to CNC controls. Saved programs, precision tooling and on-screen setup information allow operators to setup the same way every time.

The detailed job setup screen displays setup notes, tool names and tool locations. Scrap caused by handling errors is reduced as 3D part views guide the operator through each step of the bend sequence. Bend simulation can be performed offline or at the machine to check for interference and create programs without trial and error bending. Now even inexperienced operators can bend complex parts with confidence.



1. Open Program



2. Review setup information, install tooling



3. View part handling

Quick Tool Change and Crowning

Manual Clamp

The MAXFORM's Quick Clamp Ram Nose provides improved clamping and compatibility with sectionalized tools. The load capacity of the ram nose is increased from 15 to 30 tons/square inch reducing the risk of damage caused from overloaded tool segments. The modular bolt-on design simplifies maintenance if replacement is necessary. Sectionalized tools are clamped with a quick turn of the die clamp bolts located on 6" centers. The ram nose is machined with a double-hooked tongue slot allowing tools with a safety tongue to be easily reversed.



Standard Quick Change Ram Nose

Power Clamp

The optional GINCINNATI Power Clamp Upper system is also ideally suited for sectionalized tools. It's hardened to withstand 30 tons/square inch loading capacity, machined with a double hooked tongue slot and has a narrow profile for minimal part interference.

The versatile ram design allows the machine to be optionally equipped with a variety of hydraulic clamping systems. Lower hydraulic clamping systems are also available options on the MAXFORM.



Optional GINCINNATI Power Clamp

Crowning

On long parts, bed and ram deflection can cause angular variations along the bend. The standard Microcrown machined into the bed produces a parallel bed and ram at two-thirds of the machine capacity.

The optional AUTO CROWN® cylinder located in the bed produces an upward force proportional to the forming load improving angular consistency along the bend line.

On the MAXFORM, the programmable AUTO CROWN® gives the operator unmatched control of the results. CNC Crownable Filler Blocks are also available options.



Optional Programmable AUTO CROWN®

AUTO CROWN® is a registered trademark of Cincinnati Incorporated

Advanced Backgages



Standard 5-Axis Backgage

The GINCINNATI low profile 5-Axis and 6-Axis LT backgages provide fast positioning speeds, flip backgage fingers with hardened dowel pins, 40" gage points and auto flange correction input. The optional 6-Axis LT backgage is the first in the industry to use linear motor drives, improving speed and durability.



Flange Correction Input



Optional 6-Axis LT Backgage

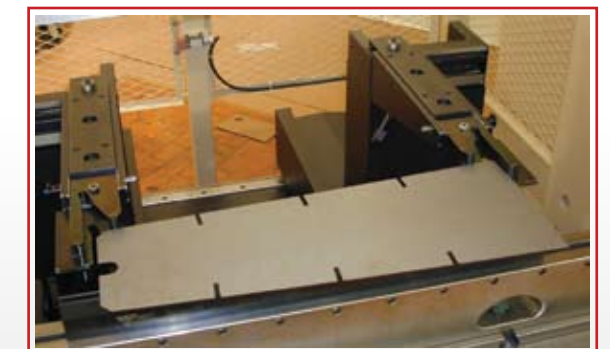

Optional Combinational Gage Fingers on 6-Axis LT Backgage